

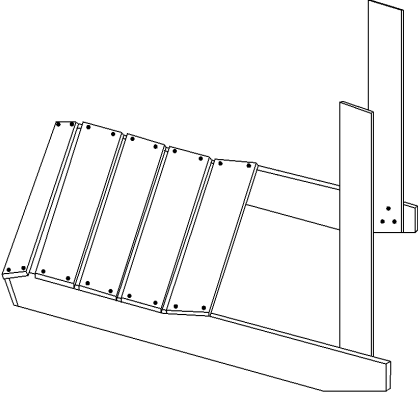
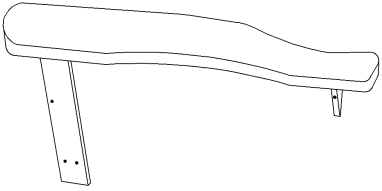
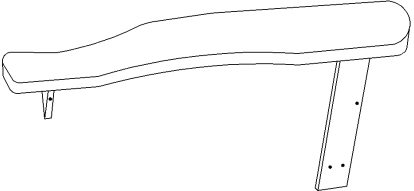
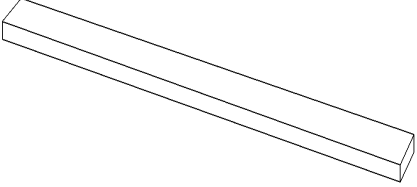
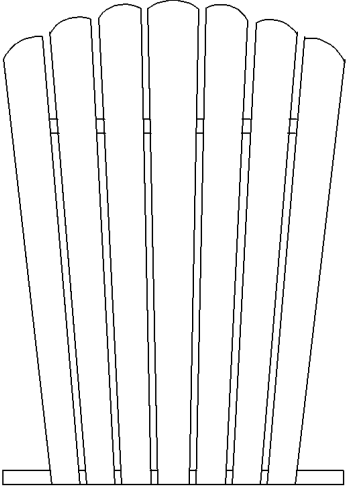

CX-07

PARTS LIST:

<p>A. Seat (with back legs) Qty: 1</p> 	<p>B. Right Arm (with front leg) Qty: 1</p> 	<p>C. Left Arm (with front leg) Qty: 1</p> 
<p>D. Stringer Qty: 1</p> 	<p>E. Back Qty: 1</p> 	

HARDWARE LIST:

1. Screws Qty: 30

Note:

- Read these instructions carefully before assembling.
- Tools required: #2 Phillips driver and power drill.
- Find a clean, smooth area on which to work, such as a carpet, in order to avoid scratching the plastic surfaces.
- It might be helpful to use the shipping carton in step 1 and 2.
- Wait to dispose of the packing material until assembly is complete and all parts and hardware are accounted for.
- Two people might be required for assembly.

Step 1: Set the Seat (A) with attached back legs on the shipping carton with the Seat facing down. Using the factory-installed screw as a pivot, rotate the back legs approximately 300°, until the ends are flush with the long angled edge. Secure each leg with an additional Screw in the counter-sunk holes provided.

Item	Description	Qty
A	Seat	1
1	Screws	4

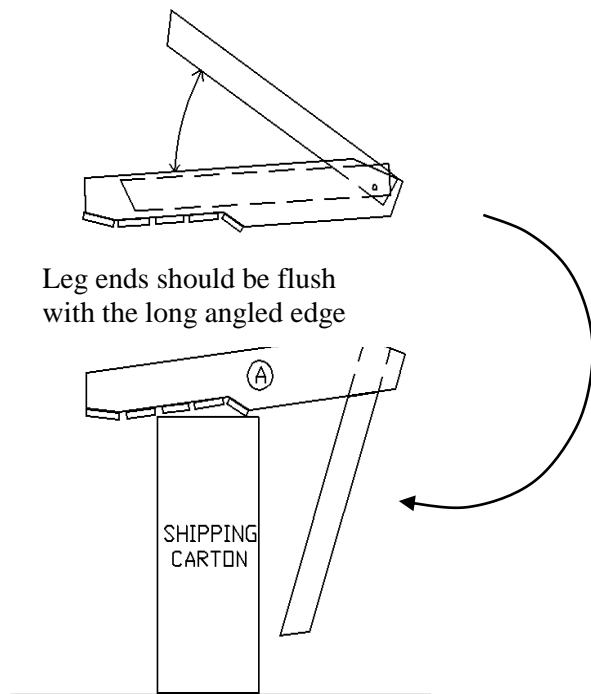

Step 2: Set the Seat (A) on the shipping carton as shown. Insert two Screws through the holes in the Seat that are closest to the front of the chair. Align the screws with the two indentations in the leg and secure the screws into the leg. Drive a third screw into the third hole. Repeat for Left Arm (C).

Step 3: Use four Screws to attach the Stringer (D) between the two front legs.

Item	Description	Qty
B	Right Arm	1
C	Left Arm	1
D	Stringer	1
1	Screws	12

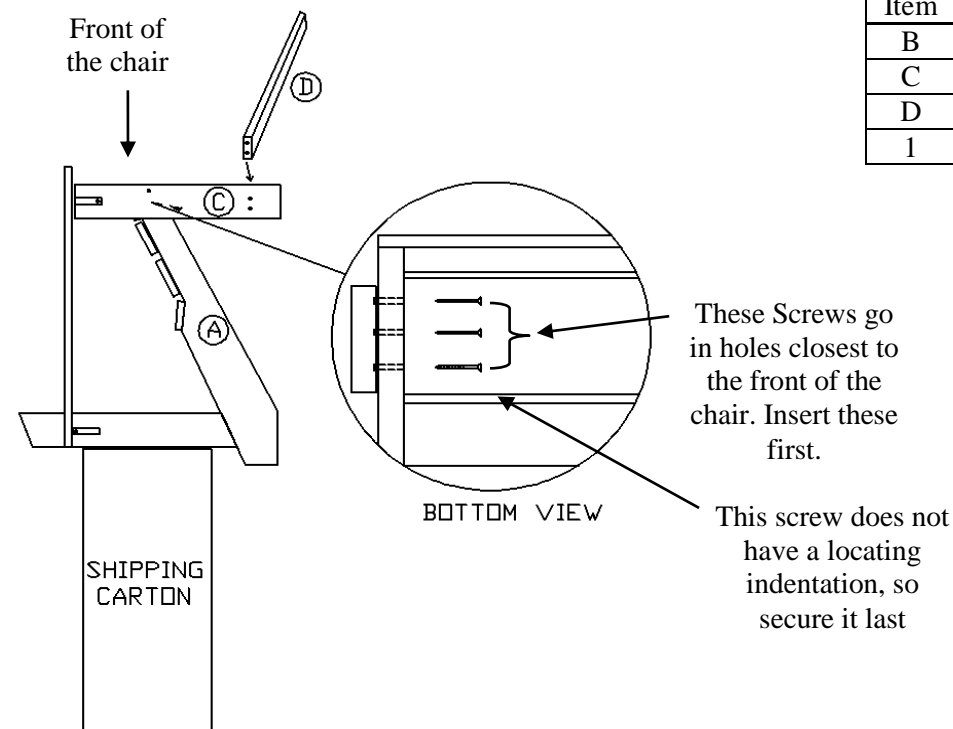

Step 4: Stand the assembly on its legs and secure the Arm (C) to the Back Leg (A) using the upper 2 holes on the Back Leg (the back edge of the arm should be flush with the edge of the Back Leg). Use a screw into the third hole on the Back Leg (A) to secure the small triangular block to the Back Leg (A). Repeat for Right Arm B.

Item	Description	Qty
1	Screws	6

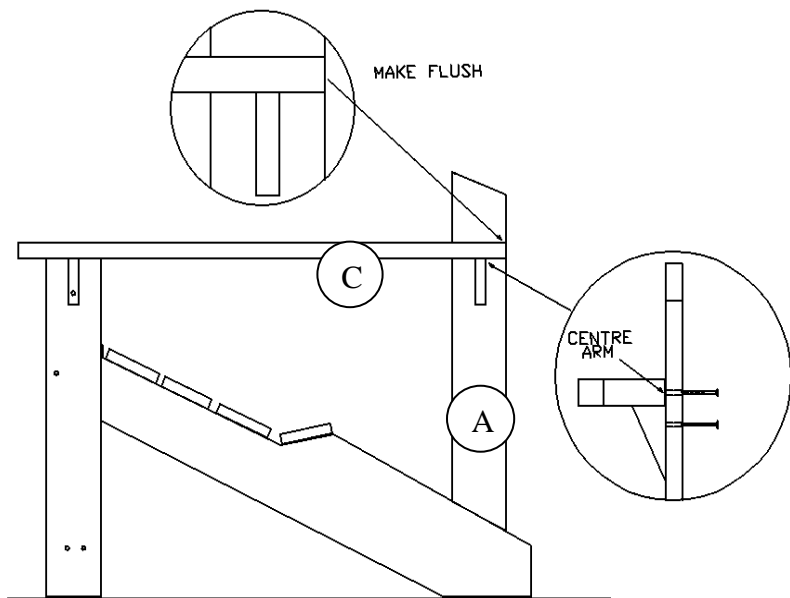

Step 5: Note: there are four locations to attach the Back (E). Begin with only one screw at each location, then adjust the chair so the pieces are square, and insert the second screw at each of the four locations. Place the Back (E) on the Seat (A) and back legs. Place one screw through the Back lower brace into the indentation in the Seat side rail (see Fig. X). Repeat on the other side.

Make the back edge of the Back upper brace flush with the back edge of the back leg (see Fig. Y). Secure with one screw. Repeat for other side of the Back upper brace.

Be sure chair is square, and insert second Screws at each

Item	Description	Qty
E	Back	1
2	Screws	8

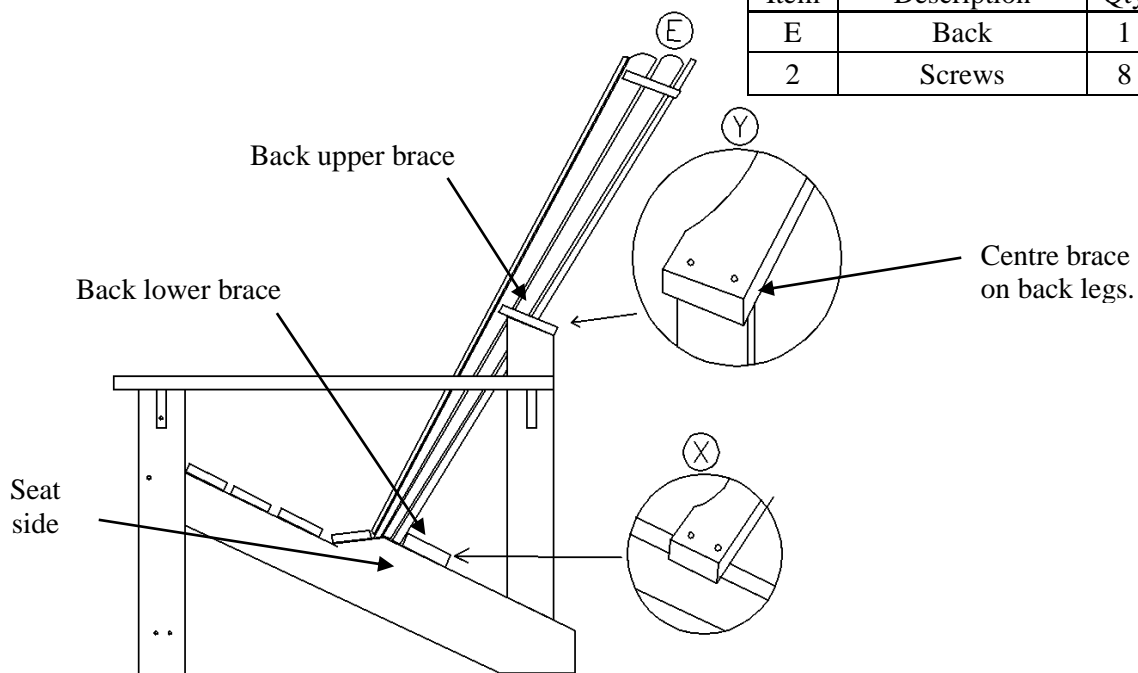

location.